

The Only GC Analyzer That Becomes MORE Accurate When Monitoring Heavier Hydrocarbon Samples



Extended Analysis

- C₉ – C₁₂ Hydrocarbon Measurement
- ≤ 50% Hydrogen

Hazardous Area Certified

- Class I Division 2 and Division 1
- ATEX / IECEx Zone 1

Low Maintenance

- Valves rated for 1,000,000 Injections
- Quick & Easy Excursion Recovery

Rapid Response

- 4 Minute Typical Analysis Sequence
- Fast and Sensitive NEMS Detector

AccuChrome™ GC Introduction

AccuChrome™ is a process analyzer that measures Btu and hydrocarbons in gas-phase samples. AccuChrome™ helps natural gas, refinery, and other industrial operators meet gas quality requirements and optimize process control.

AccuChrome™ uses thermal conductivity detection (TCD) to measure most gas compounds. Monitoring changes in electrical resistance allow AccuChrome™ to calculate the concentration of each parameter.

AccuChrome™ is a 3rd-generation GC backed by Galvanic's 40 years of field-proven experience supporting gas processing industries.



New NEMS Method Offers Speed and Sensitivity

Nano-Electromechanical Sensor (NEMS)

When measuring hydrocarbons heavier than C₇, AccuChrome™ uses a NEMS detector. NEMS ironically becomes more sensitive for heavier samples and offers 1 ppm sensitivity C₇ to C₁₂. The NEMS detector is used side-by-side with the standard TCD, offering an unparalleled package for extended natural gas analysis.

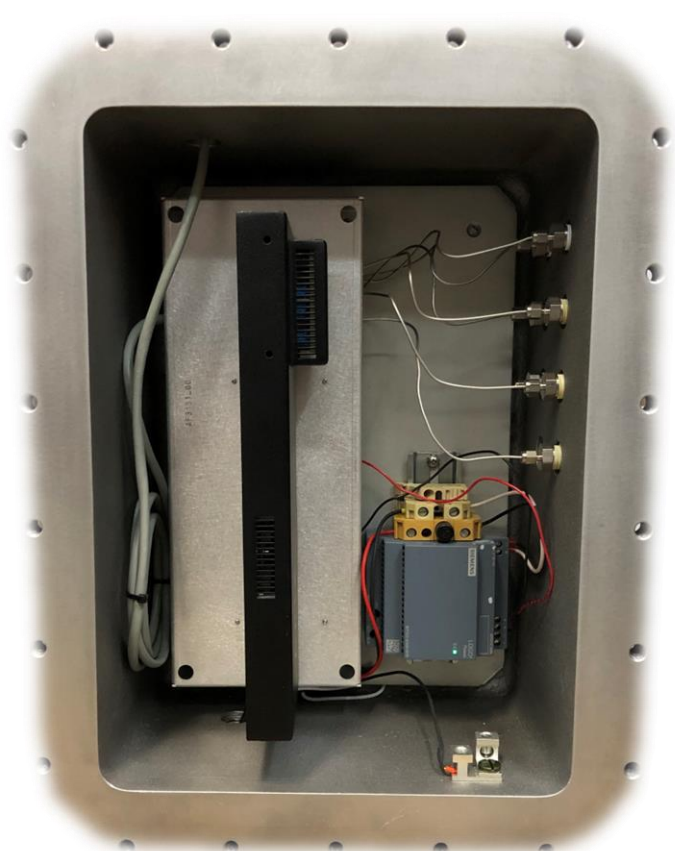
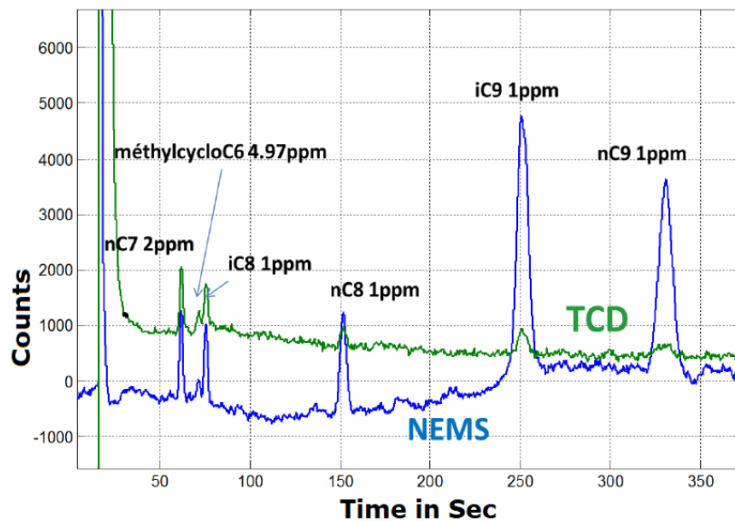

AccuChrome™ Gas Chromatograph (GC)

Btu, H₂ & C₉ - C₁₂ for Total Measurement Certainty

GALVANIC
APPLIED SCIENCES

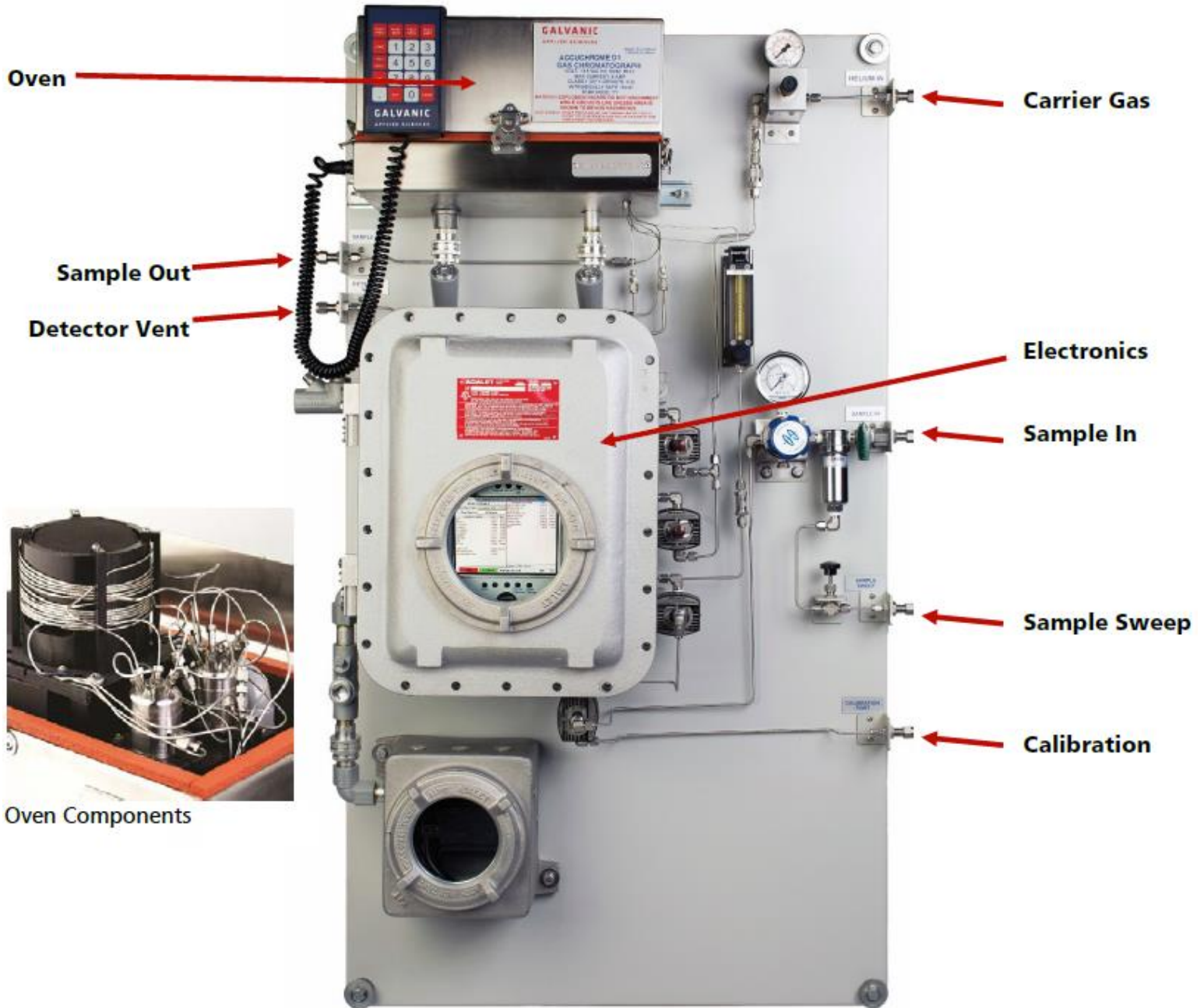

Key Components

AccuChrome™ Gas Chromatograph (GC)
Btu, H₂ & C₉ - C₁₂ for Total Measurement Certainty

GALVANIC
APPLIED SCIENCES

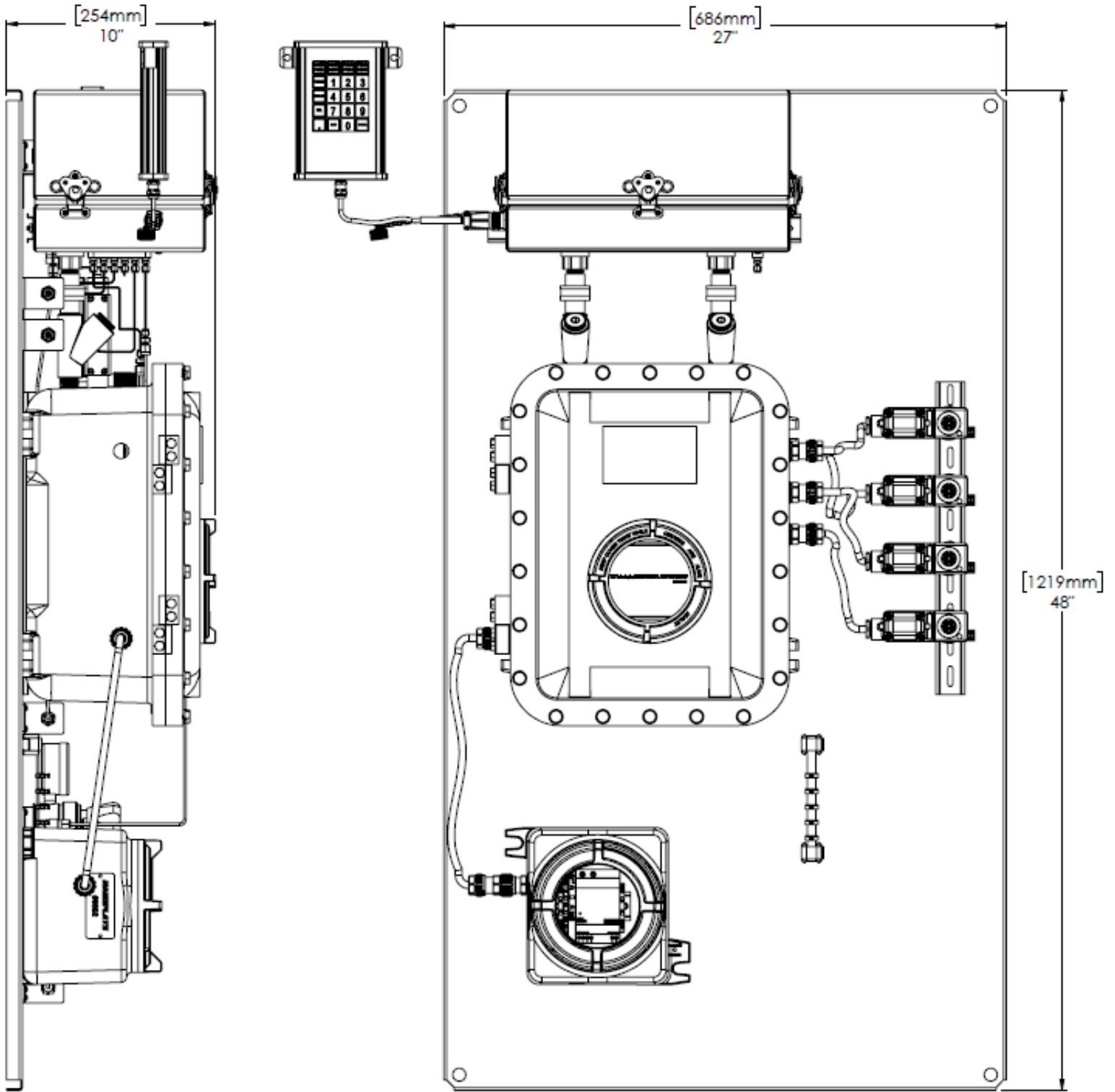

Engineering Drawing for ATEX / IECEx Zone 1 Configuration

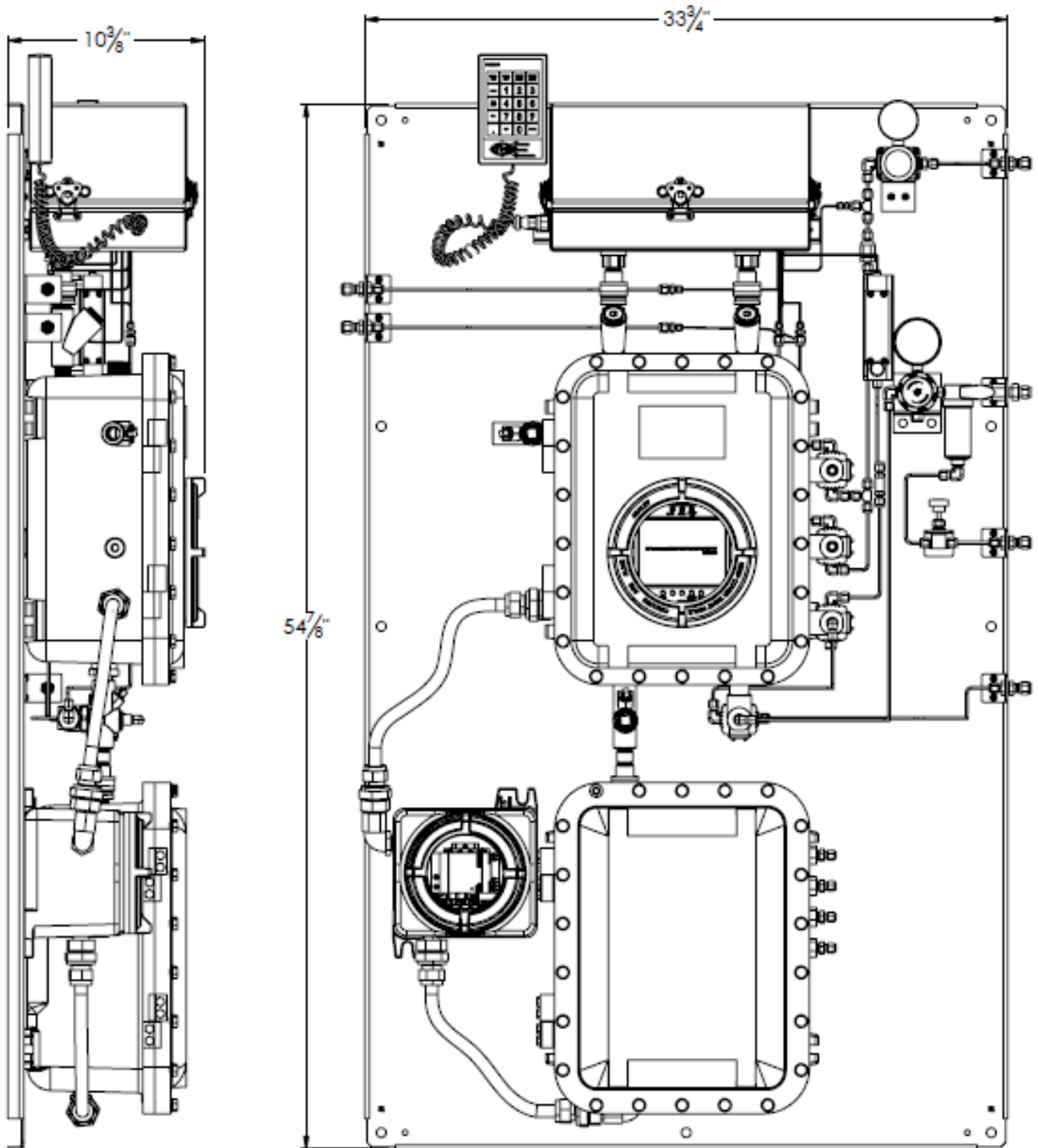

Engineering Drawing for Class I Division 1 Configuration for C9 – C12

AccuChrome™ Gas Chromatograph (GC)
Btu, H₂ & C9 - C12 for Total Measurement Certainty

GALVANIC
APPLIED SCIENCES

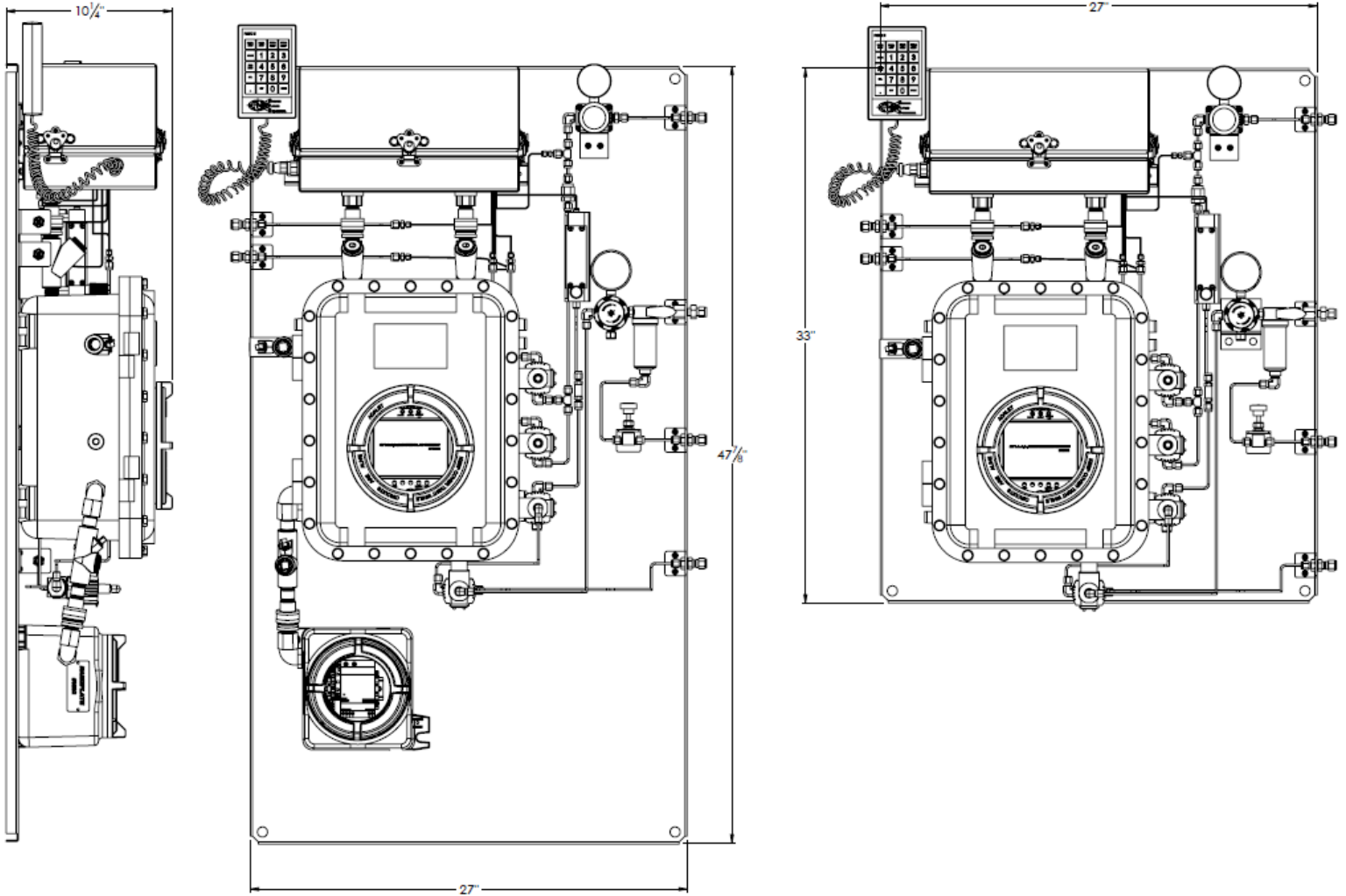

Engineering Drawing for Class I Division 1 and Division 2 Configuration for C7+

Compounds	Btu, Specific Gravity, Wobbe Index, Oxygen, CO, C6+ - C12+, N ₂ , Methane, CO ₂ , Ethane, H ₂ S, Propane, Iso-Butane, n-Butane, Iso-Pentane, n-Pentane, Neo-Pentane, Hydrogen		
Sample Handling	Vapor, Vaporizable Liquid, and Liquid Samples		
Accuracy	± 0.25% Btu/scf per 1,000 Btu/scf or ± 0.5% to 2% F.S. [Application-Specific]		
Repeatability	± 0.25% Btu/scf per 1,000 Btu/scf or ± 0.5% to 2% F.S. [Application-Specific]		
Sensitivity	200 ppm < C7+ or 1 ppm > C7+		
Method(s)	Thermal Conductivity Detection (TCD) for Compounds Lighter Than C7+ Nano-Electromechanical Sensor (NEMS) for Compounds Heavier Than C7+		
Response Time	4 Minutes [Application-Specific]		
Carrier Gas	Helium or Hydrogen at 4.1 bar, 20 cc/min [60 psi]		
Analog Outputs	4 x 4-20mA Outputs (Loop or Self-Powered)		
Analog Inputs	3 x 4-20mA Inputs [RTD, 4-20mA, Transducer]		
Modbus	TCP/IP, RS232, or RS485		
Digital Outputs	4 x SPDT Relays		
Digital Inputs	4 Discrete Inputs		
Remote GUI	Ethernet Accessible		
Analyzer Display	Color LCD With Extendable Keypad		
Ambient Conditions	-20 to 60°C [-4° to 140°F] with 0 to 95% non-condensing relative humidity -20 to 50°C [-4° to 122°F] with NEMS		
Dimensions	686 x 838 x 318 mm [27" x 33" x 12.5"] / 838 mm (48") High with VAC Power Supply 838 x 1219 x 318 mm [33" x 48" x 12.5"] With NEMS		
Power	24 VDC or 90 to 240 VAC		
Power Consumption	100 Watts Start-up, 50 Watts Running 150 Watts With NEMS		
Model	Class I Division 2	Class I Division 1	Class I Zone 1
C9 Capability	No	Yes	No
Enclosure Material	Stainless Steel	Cast Aluminum	Cast Aluminum
Enclosure Rating	NEMA 4 / 4X, IP65	NEMA 4 / 4X / 7, IP65	NEMA 3, IP54
Enclosure Weight	38.6 kg. [85 lbs.]	54.4 kg [120 lbs.] 81.6 kg [180 lbs.] With NEMS	54.4 kg [120 lbs.]
Area Classification	Class I Div. 2 Groups BCD T3 Measurement Canada	Class I Div. 1 Groups BCD T3 Measurement Canada	II 2 G Ex db [ia Ga] IIB +H ₂ T3 Gb T _{amb} -20 ≤ Ta ≤ 60C



AccuChrome™ Gas Chromatograph (GC)
Btu, H₂ & C9 - C12 for Total Measurement Certainty

GALVANIC
APPLIED SCIENCES

Digital Copies Available

